



FloCal-30

Advanced Flow Calibrator

Instruction Manual



Tisch Environmental, Inc.

The Global Standard in Air Quality Monitoring

Tisch Environmental is a 100% employee-owned manufacturer of cutting-edge technologies for environmental sampling, where precision and reliability are paramount.

Customer Support

For technical support, replacement parts, or general inquiries, please contact Tisch Environmental customer support:

Local: +1 (513) 467-9000

Toll Free: (877) 263-7610

Email: sales@tisch-env.com

Website: tisch-env.com

Thank you for purchasing the Tisch Environmental FloCal-30.

Please carefully unpack the unit and verify that all components and accessories listed below are included. If any items are missing or damaged, or if you have any questions or concerns, please contact the Tisch Environmental customer support team before attempting operation of the unit.

Included Accessories

- NIST Calibration Certificate
- 1- $\frac{1}{4}$ in. Pipe Adapter Set
- $\frac{1}{4}$ in. Barb Adapter Set
- 3 ft. $\frac{1}{4}$ in. ID Tubing
- Ambient Temperature Probe
- Bluetooth Antenna
- Durable Carrying Case
- USB-C Cable

Calibration Requirements

In accordance with U.S. EPA requirements, this instrument must be recertified annually. Refer to **1.4 Recertification** (page 8) for instructions on how to send your calibrator in for recertification.

Contents

| | |
|------------------------------------|----|
| 1.0 Introduction | 6 |
| 1.1 FloCal-30 Overview | 6 |
| 1.2 Copyrights and Trademarks..... | 7 |
| 1.3 Warranty..... | 7 |
| 1.4 Recertification | 8 |
| 2.0 Getting Started | 10 |
| 2.1 Overview and Features | 10 |
| 2.2 Specifications..... | 11 |
| 3.0 Interface Overview | 13 |
| 3.1 Interface Navigation | 13 |
| 3.2 Main Screen | 14 |
| 3.3 Flow Averaging Screen | 16 |
| 3.4 Settings Screen | 17 |
| 3.5 About Screen | 18 |
| 4.0 Operation..... | 19 |
| 4.1 Power | 19 |
| 4.2 Charging..... | 19 |
| 4.3 Adapter Installation..... | 20 |

| | |
|--|----|
| 4.4 Reading Flow Measurements | 21 |
| 4.5 Using the Temperature Probe..... | 23 |
| 5.0 Bluetooth and App Usage..... | 25 |
| 5.1 Downloading the FloCal-30 App..... | 25 |
| 5.2 Pairing with the FloCal-30 | 25 |
| 6.0 Troubleshooting and Technical Support..... | 27 |
| 6.1 Inlet Cap Cleaning | 27 |
| 6.2 Coin Cell Battery Replacement..... | 27 |
| 6.3 Forced Reset..... | 31 |
| 6.4 Customer Support..... | 31 |
| 7.0 Appendix A: Revision history | 31 |

1.0 Introduction

1.1 FloCal-30 Overview

The Tisch Environmental FloCal-30 is an advanced, NIST-traceable flow calibrator designed for standardized, reliable results and ease-of-use. Representing the latest technology in a compact and durable format, this device is intended for use with a variety of standard FRM and FEM air samplers.

The FloCal-30 accurately measures volumetric and standard flow, relative humidity, and barometric pressure. The 0.5-30 SLPM calibration range ensures maximum compatibility across diverse monitoring equipment. For seamless operation, integrated Bluetooth pairs quickly with Android™ or iOS devices, allowing users to view real-time data via the FloCal app. Additionally, the internal lithium-ion battery delivers up to 18 hours of continuous use for remote, cord-free operation.

Combining modern technology for communication and easy set-up, the FloCal-30 is designed with the user in mind for accurate on-site calibration and rapid results.

1.2 Copyrights and Trademarks

The FloCal-30 trade name and Tisch logos are copyrights of Tisch Environmental, Inc. The software and hardware design used in this instrument is proprietary intellectual property of Tisch Environmental and is not to be reproduced or replicated in any way.

1.3 Warranty

Instruments manufactured by Tisch Environmental, Inc. are guaranteed to be free of defects in materials and workmanship for one year after shipment from Tisch Environmental factories. The liability of Tisch Environmental, Inc. is limited to servicing or replacing any defective part of any instrument returned to the factory by the original purchaser. All services traceable to defects in original materials or workmanship are considered warranty service and is performed free of charge. Warranty shipping charges to and from our factory will be borne by Tisch Environmental. Service performed to rectify an instrument malfunction caused by abuse, acts of God, or neglect, as well as service performed after the one-year warranty period, will be charged to the customer at current prices for labor, parts, and transportation. Tisch Environmental reserves the

right to make changes in construction, design specifications, and prices without prior notice.

1.4 Recertification

In accordance with USEPA requirements, this instrument should be recertified annually if being used for the calibration or auditing of EPA designated air monitoring systems.

NIST recertification is performed at our laboratory in Cleves, Ohio.

To begin the process, complete the recertification form on our website or contact the Tisch Environmental Recertification Team:

Local: +1 (513) 467-9000

Toll Free: Toll Free: (877) 263-7610

Email: recal@tisch-env.com

Website: tisch-env.com/calibrator-recertification

Shipping Address

Tisch Environmental, Inc.
Attention: Recalibrations
145 South Miami Ave
Cleveland, OH 45002
U.S.A.

Recertification Time

Recertification is typically completed within one week of receipt. Expedited service may be available upon request.

Instructions

After initiating service, ship the unit to the address listed. Upon receipt, the unit will be calibrated and returned with full certification documentation.

2.0 Getting Started

2.1 Overview and Features

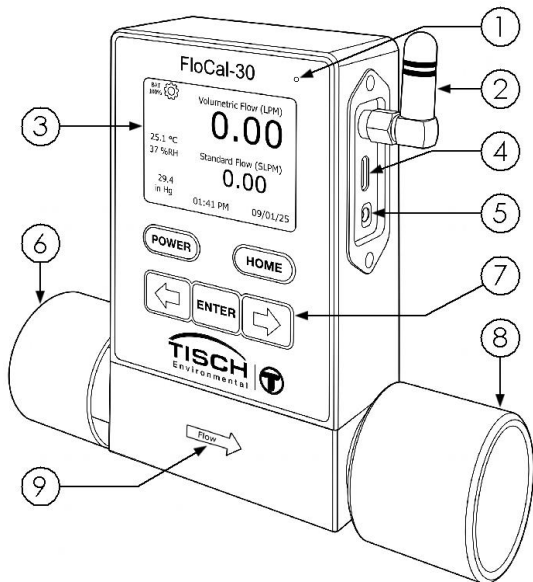

| Item | Description |
|------|---|
| 1 | Battery charging indicator light |
| 2 | Bluetooth antenna |
| 3 | 2.3 in. sunlight-readable TFT LCD |
| 4 | USB-C charging port/ firmware update port |
| 5 | Jack for external temperature probe |
| 6 | Inlet cap |
| 7 | Tactile control buttons |
| 8 | Outlet |
| 9 | Flow direction indicator |

2.2 Specifications

Parameters

| | |
|--------------------------------|---|
| Flow Range: | 0.5-30 SLPM |
| Flow Range Units: | LPM and SLPM |
| Flow Accuracy: | $\pm 1.5\% < 2 \text{ SLPM} < \pm 1\%$ of reading |
| Display Resolution (Flow): | 0.01 LPM |
| Barometric Pressure Range: | 400-900 mmHg |
| Barometric Pressure Accuracy: | $\pm 3 \text{ mmHg}$ |
| Display Resolution (Pressure): | 0.1 mmHg |
| Pressure Units: | mmHg, mbar, kPa, inHg, or Pa |
| Temperature Units: | $^{\circ}\text{C}$ or $^{\circ}\text{F}$ |
| Temperature Accuracy: | $\pm 0.1^{\circ}\text{C}$ |
| Display Resolution (Temp): | 0.1°C , 0.1°F |
| Relative Humidity Range: | 0-100% non-condensing |
| Relative Humidity Accuracy: | $\pm 1.5\%$ |
| Operating Temperature Range: | -30°C to 60°C |
| Operating Humidity: | 0-100% non-condensing |

Connectivity

| | |
|-----------------|--|
| Communication: | Bluetooth (BLE) |
| User Interface: | Mobile app (iOS/Android) |
| FloCal-30 App: | Real-time monitoring of flow and system parameters |

Electrical

| | |
|------------------|--|
| Power: | Internal lithium-ion 7.4 Wh battery |
| Charging: | USB-C |
| Display: | 2.3 inch TFT LCD |
| Battery Life: | 18 hours (continuous ON condition) |
| Recharging Time: | 4.5 hours (with 2A USB-C charger and device off) |

Physical

FloCal-30 (without adapters):

| Weight | Width | Height | Depth |
|--------------------|------------------------|-------------------------|-----------------------|
| 15.2 oz (431 g) | 2.7 inches (6.9 cm) | 4.7 inches (11.9 cm) | 1.3 inches (33 cm) |

Carrying Case with Accessories and Calibrator:

| Weight | Width | Height | Depth |
|-----------------------|--------------------------|--------------------------|-------------------------|
| 5 pounds (2.25 kg) | 14.3 inches (36.3 cm) | 11.1 inches (28.2 cm) | 4.7 inches (11.9 cm) |

Specifications are subject to change without notice.

3.0 Interface Overview

3.1 Interface Navigation

The FloCal-30 user interface consists of four primary screens:

1. **Main Screen**

Displays real-time flow measurement data.

2. **Flow Averaging Screen**

Allows users to view average flow over a chosen time interval.

3. **Settings Screen**

Provides options to configure device parameters, including measurement units, date, and time.

4. **About Screen**

Displays device information such as serial number and next calibration date.

Users can cycle through these screens by pressing the **HOME** button.

Each screen includes specific navigation options and functions, as described in the following sections.

3.2 Main Screen

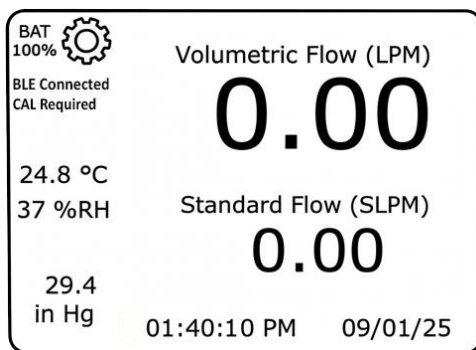

The **Main Screen** displays real-time measurement data for the following parameters:

- Volumetric flow
- Standard flow
- Temperature
- Relative humidity
- Barometric Pressure

Before taking measurements, ensure the device is zeroed. To zero the device, press and hold the **ENTER** button while on the **Main Screen**.

The current time and date are also shown on this screen.

When the device is due for calibration, a **CAL Required** notification is displayed on the left side of the screen to alert the user.

A battery level indicator is in the upper-left corner of the display. The indicator color changes according to the remaining battery level:

| Battery Level | Color |
|----------------------|--------------|
| (70-100%) | Green |
| (33-70%) | Orange |
| (0-33%) | Red |

When a Bluetooth connection is active, a **BLE Connected** status message appears below the battery indicator.

Screen brightness can be adjusted using the **Left Arrow** and **Right Arrow** buttons.

3.3 Flow Averaging Screen

Average Flow

Time : Sec
Select the average time to start

| | | |
|----------------|--------|------|
| Average Flow : | 0.00 | LPM |
| | : 0.00 | SLPM |
| Temperature : | 0.0 | °C |

The **Flow Averaging Screen** allows users view average flow over a defined time interval.

Use the **Left Arrow** and **Right Arrow** buttons to select a time interval between 1 and 20 seconds. Once the desired interval is selected, press the **ENTER** button to confirm.

After setting the time interval, press the **ENTER** button again to begin the averaging process. The device will then start to measure flow over the selected duration.

At the end of the interval, the screen displays the average flow rate and average temperature.

3.4 Settings Screen

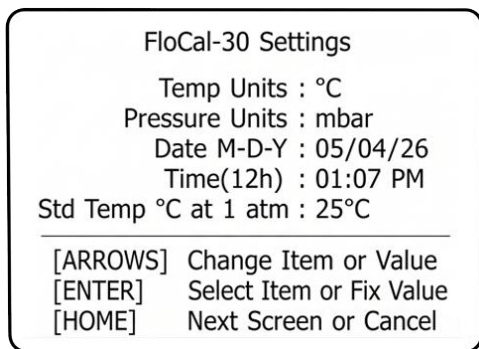

The **Settings Screen** allows users to configure device settings, including measurement units, date, and time.

Use the **Left Arrow** and **Right Arrow** buttons to navigate the list of settings in the left column. When the desired setting is highlighted, press the **ENTER** button to move to the right column.

In the right column, use the **Left Arrow** and **Right Arrow** buttons to select the desired value or unit. Once the selection is made, press the **ENTER** button to confirm.

Repeat this process as needed to configure additional settings.

3.5 About Screen

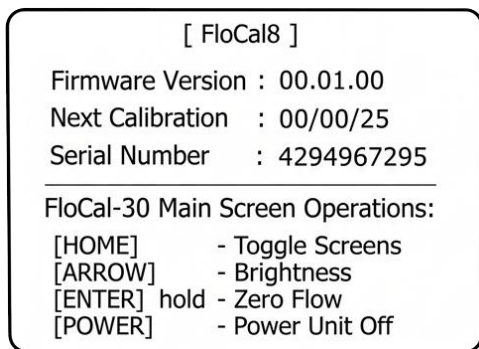

The **About Screen** displays device information, including the device name at the top, followed by the firmware version, next calibration date, and serial number.

This screen also provides **Main Screen operation instructions** for user reference.

4.0 Operation

4.1 Power

To power-on the FloCal-30, press the **POWER** button.

To power off the device, press and hold the **POWER** button for approximately one second until the unit shuts down.

The FloCal-30 is equipped with an Auto Power-Off feature that automatically turns the device off when the measured flow rate remains below 0.25 LPM for 10 minutes without any user interaction. This feature helps conserve battery life.

4.2 Charging

Power is supplied by an internal 7.4 Wh lithium-ion battery.

To charge the FloCal-30, use a **2A USB-C charger**. Use of a higher-power charging adapter is not recommended.

Under continuous operation, the FloCal-30 provides up to **18 hours of battery life**. A full recharge takes approximately **4.5 hours** when using the recommended charger with the device powered off.

The LED charging indicator will glow **Red** when the battery is charging and transition to **Green** once the device is fully charged.

4.3 Adapter Installation

The FloCal-30 is supplied with two sets of adapters:

1. **Inlet Cap and 1¼ in. Pipe Adapter Set**

Designed to fit a standard downtube on a low-volume air sampler, such as the Tisch Environmental TE-Wilbur low-volume air sampler. The Inlet cap is equipped with a debris-protection screen that may require occasional cleaning. Please see **6.1 Inlet Cap Cleaning** (page 27) for cleaning instructions.

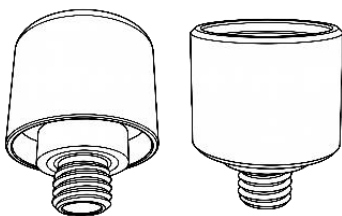

2. **¼ in. Barb Adapter Set**

Intended for use with ¼-in. ID tubing. A 3-ft length of ¼-in. ID tubing is included with each calibrator.

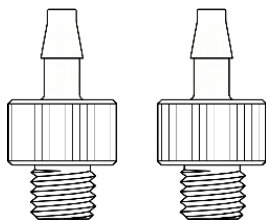

When installing either adapter set, ensure that:

1. The adapters are securely tightened onto the FloCal-30.
2. The adapters are oriented correctly so that the airflow follows the direction indicated by the airflow arrow on the calibrator.

Proper installation is critical to ensure accurate flow measurements and to prevent leaks.

4.4 Reading Flow Measurements

1. **Power On and Verify Settings**

Turn on the FloCal-30. Confirm that the time, date, and measurement units are correct.

For instructions on configuring these settings, see **3.4 Settings Screen** (page 17).

2. **Zero the Calibrator**

Before taking any readings, ensure the calibrator has been properly zeroed:

- Verify that no airflow is passing through the device.
- From the Main Screen, press and hold the **ENTER** button until the device reads zero flow.

3. **Take Flow Measurements**

Once the device has been zeroed and all settings are correct, flow data can be read directly from the Main Screen.

4. **Flow Averaging (Optional)**

To perform averaged flow measurements, see **3.3 Flow Averaging Screen** (page 16).

5. **Bluetooth Readings (Optional)**

To take readings using the FloCal-30 app, see **5.0 Bluetooth and App Usage** (page 25).

4.5 Using the Temperature Probe

The FloCal-30 is equipped with both an internal flow channel temperature sensor and an external temperature probe. The temperature displayed depends on whether the external probe is connected.

When the temperature probe is **not connected**, the Main Screen displays the flow channel temperature measured by the instrument's internal sensor.

When the temperature probe is **connected**, the Main Screen automatically switches to display the temperature measured by the probe.

Note: if the FloCal-30 is exposed to direct sunlight without sufficient flow through the flow channel, the internal temperature sensor may read higher than the external probe.

If completing a filter temperature calibration of a Tisch Environmental TE-Wilbur low-volume air sampler or other FRM/FEM system, follow the procedure described on the next page:

1. Before taking a reading, review the sampler's calibration procedure for filter temperature calibration. If using a TE-Wilbur, access the **Filter Temperature Calibration** screen using the following sequence: **Main Menu > Calibration > Filter Temperature Calibration**.
2. Ensure the external temperature probe is connected to the FloCal-30 and allow the probe to equilibrate to ambient conditions before proceeding.
3. Place the FloCal-30 external temperature probe inside the filter holder within 1 cm of the sampler's filter temperature RTD, in accordance with EPA requirements. Ensure the probe does not contact the filter media or surrounding surfaces.
4. Follow the sampler's calibration procedure to enter the filter temperature value measured by the calibrator. On the TE-Wilbur, enter the temperature value on the **Filter Temperature Calibration** screen, then press **Update Filter Temperature**.

5.0 Bluetooth and App Usage

5.1 Downloading the FloCal-30 App

The FloCal-30 mobile app is available for download from major app platforms, including the Apple App Store and Google Play Store.

The app provides a real-time mirrored display of the **Main Screen**, offering an alternative method for viewing and recording measurements.

5.2 Pairing with the FloCal-30

Once the FloCal-30 app is installed, follow the steps below to connect the calibrator to your mobile device:

1. **Enable Bluetooth**

Ensure that Bluetooth is enabled on your mobile device and that the app has been given permission to use Bluetooth.

2. **Power On the FloCal-30**

Turn on the calibrator. The device will begin broadcasting a Bluetooth signal.

3. **Open the FloCal-30 App**

Launch the app. It will automatically connect to the FloCal-30 and begin mirroring the data.

Note: the initial connection range and reconnection range may differ. If the device disconnects, move closer to the FloCal-30, then close and reopen the app to reconnect.

Once successfully connected, **BLE Connected** will appear on the left-hand side of the FloCal-30 screen confirming an active Bluetooth connection.

If multiple FloCal-30 devices are in use, the app automatically connects to the device with the strongest Bluetooth signal. If the app connects to the wrong FloCal-30, tap the Bluetooth icon in the upper-left corner to display a list of available devices within range, then select the desired FloCal-30 from the list.

6.0 Troubleshooting and Technical Support

6.1 Inlet Cap Cleaning

The inlet cap is equipped with a debris-protection screen and an O-ring that secures the screen in place. Periodic cleaning may be required to remove accumulated debris and ensure proper airflow.

Cleaning process:

1. Remove inlet cap from the FloCal-30.
2. Carefully remove the O-ring to release the screen.
3. Clean the screen using a soft brush and water.
4. Allow the screen to dry completely before reassembly.
5. Reinstall the screen and secure it with the O-ring.

6.2 Coin Cell Battery Replacement

The FloCal-30 uses CR2032 coin cell battery to maintain the correct date and time. If the date or time is incorrect or resets, replace the coin cell battery by following the procedure described on the next page.

Required Tools:

- Phillips screwdriver
- Flat-head screwdriver
- Replacement CR2032 coin cell battery

1. Power off the FloCal-30. Using a Phillips screwdriver, remove the six (6) screws securing the back panel. Carefully lift and remove the back panel.

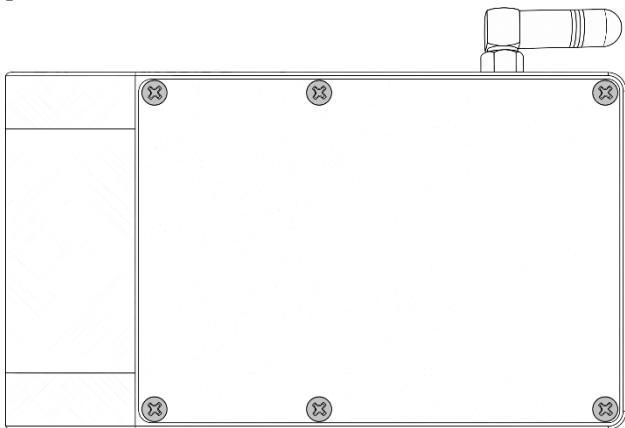

2. Disconnect the main battery pack from the PCB and set aside.

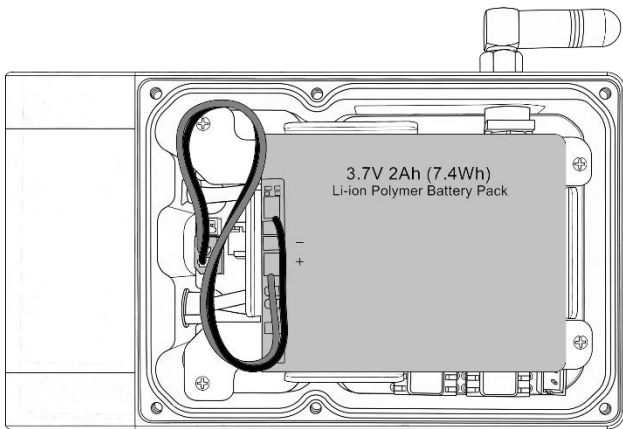

3. Remove the battery tray by removing the four (4) screws with a Phillips screwdriver. Set the battery tray and screws aside.

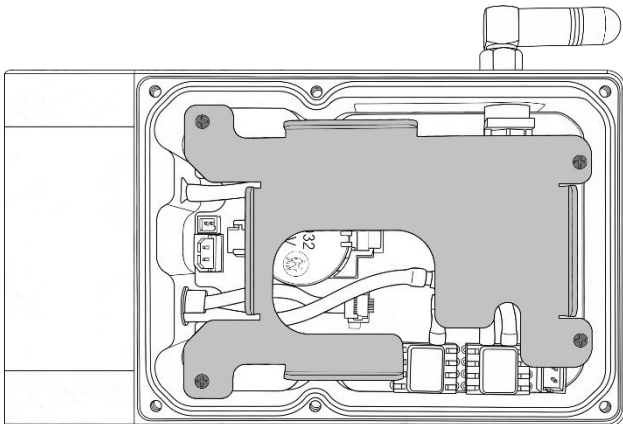

- Using a flat-head screwdriver, carefully pry the coin cell battery out from the bottom of the holder and remove it. Install a new CR2032 battery, ensuring the polarity is correct.

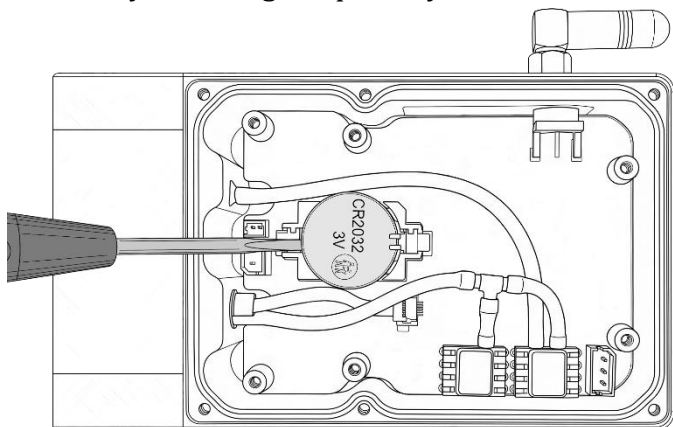

- Reinstall the battery tray and secure it with the four (4) screws.
- Reconnect the main battery pack to the PCB.
- Reinstall the back panel and secure it using the six (6) screws removed earlier.
- Power on the FloCal-30 and reset the correct time and date. For instructions on how to set the time and date see **3.4 Settings Screen** (page 17).

6.3 Forced Reset

If the FloCal-30 is powered on but becomes unresponsive, perform a forced reset by pressing and holding the **POWER** button and the **Left Arrow** button simultaneously until the device resets.

6.4 Customer Support

For technical support, replacement parts, or general inquiries, please contact us using the information below:

Local: +1 (513) 467-9000

Toll Free: (877) 263-7610

Email: sales@tisch-env.com

Website: tisch-env.com

7.0 Appendix A: Revision history

| Revision No. | Date | Description |
|--------------|----------|----------------|
| REV000.0 | 05-06-26 | Manual Created |

